



*a homeowner's
reference guide to*

STORMWATER MANAGEMENT

CONTENTS

What is stormwater and how does it affect me?	1
What are issues related to stormwater?	2
Stormwater fees	3
Stormwater credits	4
Soil testing	5
<i>How to take a soil sample</i>	
Disconnect or redirect your downspout	7
<i>Materials and costs</i>	
<i>Steps to disconnect your downspout</i>	
Rain barrels	9
<i>Construct your own rain barrel</i>	
<i>Pre-constructed barrels</i>	
<i>Additional local sources</i>	
Rain gardens	12
<i>What goes in a rain garden</i>	
<i>How to build a rain garden</i>	
<i>Rain garden costs</i>	
Native plants	15
<i>Where to get natives</i>	
<i>Natives for rain gardens</i>	
Composting	17
<i>How It Works</i>	
<i>Setting up the compost pile</i>	
<i>Selecting your compost bin</i>	
<i>What to compost</i>	
Permeable pavers	19
<i>Types and costs</i>	
<i>Install pavers yourself</i>	

Throughout this guide you will notice symbols that rate the financial cost and time commitment of various projects. These images will help you decide which projects are best for you.

FINANCIAL COST



Minimal cost



\$25-\$75



\$75-\$150



\$150 +



EFFORT OR TIME COMMITMENT



Minimal effort or time commitment



Less than two hours of work



Approximately a half-day of work



Approximately a full day of work



WHAT IS STORMWATER AND HOW DOES IT AFFECT ME?

Stormwater is water from rain or melting snow that is not absorbed into the ground. It travels down gutters and across paved surfaces, bare soil, or sloped lawns, eventually making its way to a ditch or storm drain in the street. From here the storm drain system carries that water directly to local streams and rivers.

Stormwater runoff from your yard picks up a number of pollutants on its way to rivers and streams. These harmful materials include:

- Sediment
- Fertilizer
- Pesticides
- Pet waste
- Oil, grease, gasoline, and antifreeze from vehicles
- De-icing products such as salt or chemical ice melt
- Grass clippings, leaves, and other yard waste
- Litter such as fast food wrappers and cigarette butts



Because stormwater runoff is the number one way pollutants enter our local waterways, it is critical that we be aware of what we put on the ground. As a homeowner you can play a big role in helping to manage stormwater and keep our local streams and rivers clean.

WHAT ISSUES ARE RELATED TO STORMWATER?

The problem with pavement

Solid surfaces such as parking lots, roads or driveways keep rain from infiltrating the soil and recharging groundwater supplies. The infiltration process helps clean water and feed the underground springs that supply drinking water. Paved or impervious surfaces also increase the speed and amount of water that rushes into streams, causing stream bank erosion and harming wildlife habitats. An easy fix is to **direct the flow of water from downspouts away from paved surfaces** whenever possible.

Combined sewer overflows

Combined sewers are older systems that carry both stormwater and wastewater to treatment plants. When rainstorms fill combined sewers beyond capacity, the result is a **Combined Sewer Overflow** — a discharge of untreated wastewater and stormwater into local waterways. Combined sewers are costly to replace and increase the cost to treat and clean drinking water. Residents are encouraged to disconnect downspouts from sewer pipes and use rain barrels or redirect downspouts to grassy areas or gardens to reduce the amount of rain entering sewers.

Getting to the root of stormwater problems

The dense clay soils in our region make it difficult for water to soak into the ground quickly. As natural vegetation is replaced with popular turf grasses, less stormwater is absorbed into the ground, leading to more stormwater runoff and water pollution. **Native plants** have deeper root systems that substantially increase the ability of soil to absorb and retain water.

Roof runoff

The average rainfall of one inch within a 24-hour period can produce more than 700 gallons of water that runs off the roof of a typical site. Much of this water runs from gutters onto impervious ground surfaces such as streets or driveways, sweeping pollutants into storm drains and eventually into our rivers and streams. A **rain barrel** can collect and store fresh rainwater from downspouts and rooftops for future use watering lawns and gardens and reduces the amount of rainwater and pollutants that wash into our waterways.

WHAT ARE STORMWATER FEES?

Most homeowners pay a stormwater fee that helps a community maintain its stormwater system. This fee could be collected monthly, included in a water or other city utility bill, or paid once annually along with property taxes. Stormwater fees range across the region but are generally either a flat or tiered rate based on the amount of impervious surface on a piece of property.

Due to aging infrastructure, stormwater fees across the region are likely to increase in the future, many residents are looking for ways to reduce their property's stormwater output and avoid higher fees.



Many jurisdictions give stormwater credits to households that demonstrate efforts to reduce stormwater runoff by using best management practices because they reduce stress on the stormwater system. Many of the practices presented in this guide can help you conserve water on your property and even reduce your stormwater fees. You can save money and protect the health of the environment and your community at the same time.

HOW STORMWATER CREDITS WORK

Kansas City, Mo., offers two types of **stormwater fee credits**. The first is a ***ratio credit***. Properties that have a large pervious area to help absorb stormwater and prevent it from entering storm drains receive a ratio credit if the ratio of the total property area to the runoff surface area is at least 30:1. Properties that qualify are granted a 50 percent stormwater fee credit.

The second type of stormwater fee credit is a ***detention credit***. Stormwater detention structures are installed and maintained to reduce stormwater's peak flow and runoff volume from a drainage area, thereby reducing flooding and erosion downstream. Properties served by a privately owned and properly maintained detention structure are granted a stormwater fee credit based on the reduction of stormwater runoff provided by the detention structures and calculated according to guidelines established by the city's director of water services. The minimum credit is 10 percent and the maximum credit is 50 percent.

The property owner is responsible for applying for the ratio credit, detention credit, or both. If a property is eligible for both types of credit, the ratio credit is applied first, and the detention credit is applied to the remaining amount. The combined credit cannot exceed 75 percent.





Soil testing is an important step to take before buying fertilizer or planting. Soil testing analyzes the nutrients present in your soil and helps you avoid over-fertilizing. — It can save you time and money, and also prevent excess chemicals from running off into area waterways. Finding out how much fertilizer your lawn really needs is as simple as taking a sample of your soil to your county extension office.



How to take a soil sample

- Use a core device, auger, trowel, spade or other tool to collect core samples from six inches in depth (three inches on established lawns). Samples should be uniform in diameter.
- Take 10 or more core samples, at random, from the test area. Combine and crumble the samples, blending thoroughly in a clean container. Remove any stones, grass or roots. If the lawn has areas with distinctly different soil conditions, collect samples from each area.
- Take one cup of the soil sample mixture to your local county extension office in a small, clean, covered container or plastic bag.
- Other information you should provide to the extension office:
 - » *Name, complete mailing address and phone number*
 - » *Plant cover (lawn, vegetables, flowers, shrubs, etc.)*
 - » *Previous fertilizer applications and any other treatments*
 - » *Specific questions or concerns*

Once your soil sample is collected it can be taken or mailed to your county's soil extension office. A basic test typically costs around \$15. Results are generally provided within two to three weeks; extension staff can discuss the results of your soil test and what sort of treatment may be appropriate for your soil.

Regional Outreach and Extension Offices

Cass County — University of Missouri Extension

302 S. Main, Harrisonville, MO 64701

816/380-8460 • <http://extension.missouri.edu/cass>

Clay County — University of Missouri Extension

1901 NE 48th Street, Kansas City, MO 64118

816/407-3490 • <http://extension.missouri.edu/clay>

Jackson County — University of Missouri Extension

1106 West Main Street, Blue Springs, MO 64015

816/252-5051 • <http://extension.missouri.edu/jackson>

Johnson County K-State Research & Extension

11811 Sunset Drive Suite 1500, Olathe, KS 66061

913/715-7000 • www.johnson.ksu.edu

Leavenworth County K-State Research & Extension

500 Eisenhower Rd Suite 103, Leavenworth, KS 66048

913/250-2300 • www.leavenworth.ksu.edu

Miami County Extension

104 South Brayman, Paola, KS 66071

913/299-9300 • www.miami.ksu.edu

Platte County — University of Missouri Extension

11724 N.W. Plaza Circle, Suite 300, Kansas City, MO 64153

816/270-2141 • <http://extension.missouri.edu/platte>

Ray County Outreach & Extension

108 West North Main, Richmond, MO 64085

816/776-6961 • <http://extension.missouri.edu/ray>

Wyandotte County K-State Research & Extension

1216 North 79th Street, Kansas City, KS 66112

913/299-9300 • www.wyandotte.ksu.edu



DISCONNECT OR REDIRECT YOUR DOWNSPOUT

Did you know that each downspout on a site can drain approximately 12 gallons of water per minute during a one-inch rainfall? Most downspouts send rain water down driveways, sidewalks, and underground pipes that lead to storm drains or sanitary sewer lines. This stormwater runoff picks up pollutants off the ground and carries them into our region's lakes and streams.



Disconnecting your downspout from the sewer system or redirecting your downspout away from impervious areas is one of the simplest ways you can reduce combined sewer overflows and stormwater runoff from your property. Redirecting an already disconnected downspout is easy and inexpensive; disconnecting a downspout from the sewer system costs about \$20 and requires a small amount of work.

Materials and Costs

To disconnect your downspout from the sewer system you will need to pick up the following supplies from your local hardware store:

ITEM	APPROXIMATE COST
Sheet metal screws	\$3
Downspout elbow	\$4
Downspout extension	\$9
Standpipe cap	\$4

Estimated costs:

\$20

You will also need the following tools:

- Hacksaw
- Cordless drill
- Tape measure
- Pliers

Steps to disconnect your downspout

1. Cut the existing downspout approximately 9 inches above the sewer standpipe with a hacksaw.
2. Cap the sewer standpipe. This prevents water from going in while keeping pests from entering the pipe.
3. Attach elbow by crimping the downspout with pliers to ensure a good fit. Connect elbow to downspout using sheet metal screws. It may be necessary to pre-drill holes.
4. Attach the elbow INTO the extension and secure with sheet metal screws. Water should drain at least five feet away from the house, so direct the extension accordingly. A splash block may help direct water further away from the house.

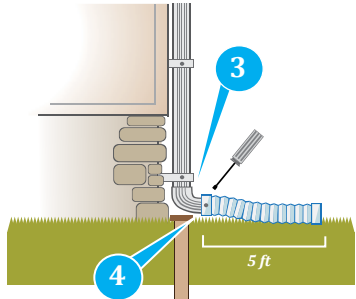
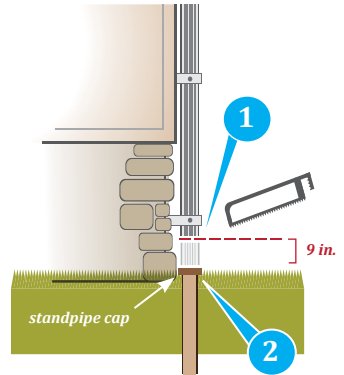
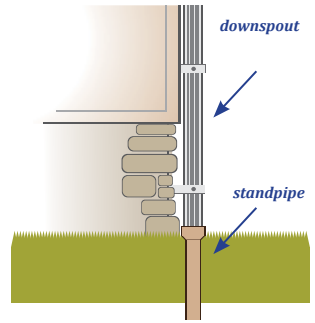

TIP

Be sure to get the most out of your rainwater by directing your new downspout extension towards gardens, grassy lawns, rain barrels, and other areas that allow water to soak into the ground. The more water absorbed or put to good use on your property, the less water goes into storm drains.



RAIN BARRELS



A rain barrel is a container that catches rainwater from downspouts and rooftops and stores it for future use, such as watering lawns, trees and shrubs or gardens. Rain barrels come in various shapes and sizes and can be bought assembled or be custom-built.

Build your own rain barrel

With a 55-gallon barrel (new or recycled) and a few parts or a kit you can easily construct your own rain barrel. Here are the supplies you'll need:



- A 55-gallon plastic barrel (*check "Additional Local Sources" in following section for pre-made or recycled barrels*)
- Two $\frac{3}{4}$ " faucets
- A $\frac{3}{4}$ " female coupling
- Skimmer basket (like those found in garden ponds and pools)
- Roll of Teflon tape
- All-purpose caulk or plumbing sealant
- 5 ft. section of garden hose
- 4-hose couplers
- 12" x 12" piece of fiberglass window screen

Construction will require the following tools:

- 1" spade drill bit
- Electric jigsaw
- Electric drill
- Utility knife
- Marker

Assembling a rain barrel

Constructing the Top Hole:

Use the basket to trace a template on the barrel. Pre-drill a small hole using 1" spade bit. Make sure to drill inside the line. Use a jigsaw to cut out the hole using inside line as a guide.



Basket:

Cut fiberglass window screen to fit basket. Affix screen to lip of basket using caulk or plumbing sealant. Allow several hours to dry and place in top hole.



Lower Drain:

Mark hole at least two inches from bottom of barrel. Use 1" drill bit to drill hole. Screw faucet into hole. Use utility knife to increase hole size as needed. Remove faucet, wrap threads in tape, caulk threads, replace faucet. Caulk area where faucet and barrel meet to ensure firm seal.



Hoses (Optional):

Cut 2' section of hose. Push each end of hose into a hose coupler and tighten screws. Screw 3' section onto top outflow faucet and 2' section to bottom faucet.



Upper Drain:

Mark holes at least two inches from top of barrel. Use 1" drill bit to drill hole. Screw plastic faucet into hole. Use utility knife as needed to alter hole. Wrap 3/4" coupling threads in Teflon tape and caulk and screw onto faucet inside the barrel.



Final Steps:

Build a base at least 6 inches above ground to elevate the rain barrel (for increased pressure and flow). Adjust downspout to flow into rain barrel. Always keep overflow valve open.



Pre-constructed barrels

Pre-assembled barrels can be purchased at most hardware or lawn care stores for around \$100. The following local organizations sell recycled 55-gallon barrels pre-assembled and in kits for reduced prices. You can contact them directly for more information.

Bridging The Gap

816/561-1087

Toll free: 1-888-895-3605

www.bridgingthegap.org

Little Blue River Watershed Coalition

816/356-4040

www.littleblueriverwc.org

Habitat ReStore

816/231-6889

www.restorekc.org

TIPS



- During the summer months it is estimated that nearly 40 percent of household water is used for lawn and garden maintenance. A rain barrel collects water and stores it for those times that you need it most — during the dry summer months.
- Using rain barrels potentially helps homeowners lower water bills while also improving the vitality of plants, flowers, trees, and lawns.
- Rain is naturally soft and devoid of minerals, chlorine, fluoride, and other harmful chemicals. The chemicals and hard water from many of our municipal water systems can add to chemical imbalances in soil and damage sensitive plants.
- Water collected from the roofs of houses picks up very little contamination, and is very healthy for plant life.



Rain gardens include flowers and plants that collect water and allow it to seep into the ground through their location and design. Rain gardens are typically bowl-shaped and placed in areas that capture and hold rainwater until it seeps into the ground. Native plants are ideal for rain gardens — their long roots are adapted to our region’s soil and help with water infiltration.



Rain gardens come in many shapes and sizes — these general steps can help you design a garden that will effectively process the rainwater that falls on your roof.

What goes in a rain garden?

Keep in mind that your rain garden, unlike a water garden, will be dry most of the time. Plants should be able to tolerate short periods of rain, but not require constant, high moisture. Select plants with moderate moisture requirements for areas that will have moist, well-drained soil. For drier sites like the edge of your rain garden, use plants that have low or moderate moisture requirements.



Want to find out which plants are right for your garden? Visit the **10,000 Rain Gardens** website and use the interactive **Find the Right Plant** feature.

www.rainkc.com

How to build a rain garden

1. Pick a naturally low spot in your yard — at least 10 feet from your house — and direct water from your downspout or sump pump into it. During heavy rains, your rain garden may fill up and overflow. Make sure this overflow drainage follows the drainage pattern originally designed for your yard. Test this by filling your depression with a garden hose and watching the overflow. If needed, dig a shallow swale to direct overflow water toward the street, road or other downhill areas away from your home.
2. Start by digging a 4-8" depression with gradually sloping sides as large in circumference as you like. (A good rule of thumb is to size your garden at 30 percent of the area of the roof from which it will collect water.) A 4-8" depth will allow water to be captured, but will dry between rains.
3. Select the appropriate vegetation. Keep in mind when selecting your native plants that it's important to plant natives that can tolerate periods of heavy rain as well as dry periods. Think about where in the bowl shape of your garden the plants will go. Plants near the rim will receive less water than those at the bottom of the bowl. Native plants have a variety of tolerance levels for sun, so think about how much sun your plants will receive.
4. Add untreated, shredded hardwood mulch to a depth of 3" on all of the bare soil around the plants to prevent erosion while your natives establish themselves.



Rain garden costs

The costs for building a rain garden can vary. A general rule of thumb is that residential rain gardens average about \$3 to \$4 per square foot*, depending on soil conditions, garden size, the level of preparation needed for the site, and the density and variety of plants selected. Determine your needs for your rain garden and contact local sources for pricing before starting the project.

Materials and services to consider:

- Native plants
- Soil amendments / compost
- Mulch
- Tools
- Labor
- Debris removal
- Excavation costs



The **10,000 Rain Gardens** website offers an **Online Calculator** that can help you estimate costs for your garden.

www.rainkc.com



TIPS

- You can save money on plants by purchasing smaller stock such as 4-inch plugs or one-gallon pots.
- Remember not to fertilize your natives. Fertilizer causes them to grow too tall and fall over. It also stimulates weed growth and creates competition for your natives.
- Newly transplanted native plants should receive water regularly until they are established. After the first year, natural rainfall should maintain your new natives if you've planted them in a place that mimics their preferred, natural habitat.



Native plants

Native plants evolved naturally in a given geographic area long before humans introduced other plants from distant places. Their local heritage gives native plants an advantage over nonnative species: they are better adapted to our region’s climate and require less irrigation and fertilizer. Most lawns in the Kansas City region are planted with non-native turf grasses like fescue. While these grasses are attractive and colorful, their short roots do not absorb and filter water effectively. Native plants also help protect the environment by filtering pollutants from our air and water, plus their roots are adept at reducing stormwater runoff.

Native plants include flowers, shrubs, grasses and trees and come in a variety of species. Their costs depend on the species and their sizes.

Natives vs. Non-Natives Root Comparison Chart

NON-NATIVES

Spirea
Spiracea sp.



Daylilies
Hemerocallis sp.



Perennial Fountain Grass
Pennisetum alopecuroides



Fescue Turf
Festuca sp.



NATIVES

Prairie Dropseed
Sporobolus heterolepsis



Black-eyed Susan
Rudbeckia fulgida



Common Ninebark
Physocarpus opulifolius



Buffalo Grass
Buchloe dactyloides



ROOT LENGTH (in feet)

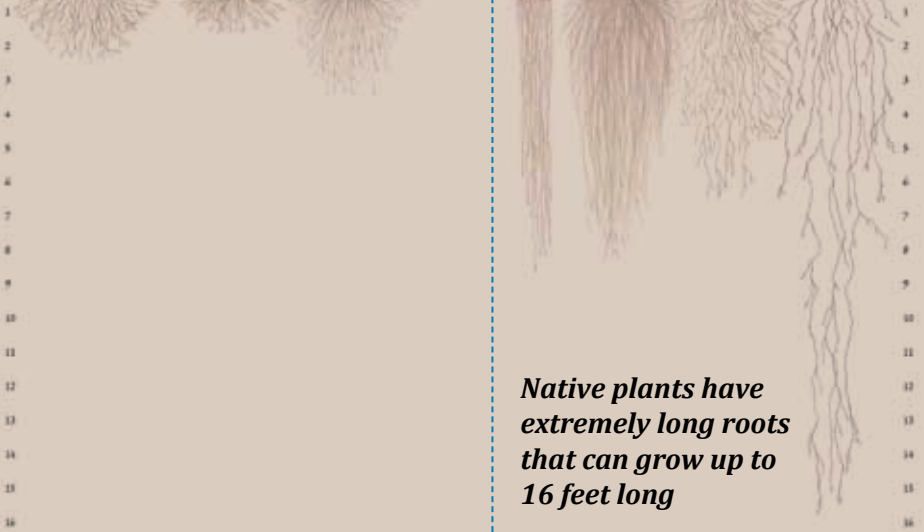

Native plants have extremely long roots that can grow up to 16 feet long

Where to get natives

Natives are often available at nurseries and garden stores throughout the region. For a large selection it may be necessary to travel to a nursery that specializes in native plants, such as these providers:

Emerald Prairie Nursery

SE Corner of K-68 and 169 Hwy
PO Box 184, Paola, Kan.
www.emeraldprairienursery.com
913/557-5700

Missouri Wildflower Nursery

9814 Pleasant Hill Rd., Jefferson City, Mo.
www.mowildflowers.net
573/496-34992

Osage Prairie Mercantile

P.O. Box 152, Clinton, Mo.
www.prairesource.com
660/885-6127

Prairie Wetland Center

16245 S. US Hwy 71, Belton, Mo.
www.critsite.com
816/331-9738



Find more area sources for rain garden products and design and installation services using the online **Where to Buy** feature:

www.rainkc.com

TIP



Select rain garden plants according to their water needs and sun exposure. Ideally, all rain garden plants should be drought-tolerant. There are generally three zones within a rain garden and your water needs should be based on the plant's location within these zones.



Composting is a practical and convenient way to handle waste from your lawn, garden or kitchen. It's a natural way of returning nutrient-rich plant matter to the soil and diverting about 1/3 of your household trash from landfills in the process.



How it works

You can create a compost pile in your backyard or indoors, depending on your available space. Backyard and indoor composting are most suitable for households to convert small quantities of organic materials — such as yard trimmings and food scraps — into compost that can be spread in garden beds, under shrubs, or used as potting soil for outdoor plants.



Before you begin composting, take time to understand how the process works. Know what materials can and can't be composted and look into the science behind the process to be aware of the elements involved in successful composting.

All composting requires three basic ingredients:

- **Browns** (Includes materials such as dead leaves, branches, twigs)
- **Greens** (Includes materials such as grass clippings, vegetable waste, fruit scraps, and coffee grounds)
- **Water**

Having the right amount of greens, browns, and water is important for compost development. Ideally, your compost pile should have an equal amount of browns to greens and alternate layers of organic materials of different-size particles. The brown materials provide carbon for your compost and the green materials provide nitrogen, while the water provides moisture to help breakdown the organic matter.

Setting up the compost pile

There's no one right way to set up your compost pile. However, following a few simple guidelines will make your compost pile more successful.

1. Select a dry, shady spot near a water source for your compost pile or bin.
2. Add your brown and green materials as you collect them, making sure larger pieces are chopped or shredded.
3. Moisten dry materials as they are added.
4. Once your compost pile is established, mix grass clippings and green waste into the pile and bury fruit and vegetable waste under 10 inches of compost material.
5. Optional: Cover top of compost with a tarp to keep it moist.
6. When the material at the bottom is dark and rich in color, your compost is ready to use (this usually occurs in two months to two years)

Selecting your compost bin

Compost piles can be open or closed, although most homeowners prefer a closed bin. A variety of bins are available for purchase at local hardware stores or can be constructed relatively cheaply. An old trash can with holes in it or an open box constructed from scrap wood are easily available materials that can be used.

What to compost



DO compost

- Vegetable scraps
- Citrus rinds
- Grass clippings
- Leaves
- Weeds
- Bark, wood ashes
- Horse manure
- Small garden clippings
- Small stalks, stems, and vines



DON'T compost

- Meat/Poultry/Fish
- Fat/Vegetable oils
- Bones
- Dairy products
- Plastics or synthetics



Permeable pavers

Permeable pavers are an environmentally friendly option for patios and walkways around your home. Stormwater runs off of traditional impervious surfaces such as concrete or asphalt. Permeable pavers, on the other hand, are porous — which allows water to filter through them. Instead of heavy runoff carrying chemicals and fertilizers into the drainage systems and then into our streams and rivers, rain water travels through the pavers and is absorbed into the ground below. You can install permeable pavers without professional assistance.



Types and costs

The cost of pavers varies depending on the type of paver selected. Below are several common paver types. Always contact your city before installing pavers or other porous materials for your driveway as restrictions and permissions often apply.

<i>TYPE OF PAVER</i>	<i>APPROXIMATE COSTS</i>
Grass/gravel pavers	Grass and gravel pavers can range in price from \$1.50 to \$5.75 per square foot of installed pavement.
Interlocking concrete paver blocks	Interlocking concrete pavers range in price from \$5 to \$10 per square foot of installed pavement.
Block and brick pavers	Costs run around the high end of concrete paver blocks.

Install pavers yourself

Installation of pavers varies depending on the type and brand of paver selected. Always follow the manufacturer's installation instructions, but general steps typically include:

1. Preparing the site. Excavation is generally needed to ensure pavers will be flush with the surrounding landscape.
2. Layers of gravel, fabric liners, and sand are generally installed to support and reinforce the surface, separate the gravel from the sand, and provide a bed for the pavers.
3. Pavers are then generally installed on top of the bed of sand.
4. Space between the pavers can be filled in with sand, gravel, or plants depending on the type of pavers used.
5. Finally, your pavers will need to be compacted for a solid surface. Compaction could occur by hand or with a mechanical compactor depending on the type of paver.

Why use permeable pavers?

- Reduces stormwater runoff, flooding, and erosion to stream beds and river banks.
- Reduces installation costs of drainage systems
- Improves water quality





*Kansas City, Missouri
Water Services Department
4800 E. 63rd St., Kansas City, MO 64130*

*The Kansas Department of Health and
Environment has provided financial assistance to
this project through EPA Section 319 Nonpoint
Source Pollution Control Grant No. 2008-3003.*